

(12) INTERNATIONAL APPLICATION PUBLISHED UNDER THE PATENT COOPERATION TREATY (PCT)

(19) World Intellectual Property Organization
International Bureau



(43) International Publication Date
10 May 2001 (10.05.2001)

PCT

(10) International Publication Number
WO 01/32299 A1

- (51) International Patent Classification⁷: B01D 63/02, 63/06
- (52) International Application Number: PCT/NL00/00794
- (22) International Filing Date:
2 November 2000 (02.11.2000)
- (25) Filing Language: English
- (26) Publication Language: English
- (30) Priority Data:
1013465 2 November 1999 (02.11.1999) NL
- (71) Applicant (for all designated States except US): STORK FRIESLAND B.V. [NL/NL]; Stationsweg 84, NL-8401 DT Gorredijk (NL).
- (72) Inventors; and
- (73) Inventors/Applicants (for US only): FUTSELAAR, Harry [NL/NL]; Willem Alexanderstraat 16, NL-7511 KH Enschede (NL). HOOGEVEEN, Paul, Erik [NL/NL]; Olympiaplein 5, NL-7552 BK Hengelo (NL).
- (74) Agent: RIEMENS, R., H.; Exter Polak & Charlouis B.V., P.O. Box 3241, NL-2280 GE Rijswijk (NL).
- (81) Designated States (national): AE, AG, AL, AM, AT, AU, AZ, BA, BB, BG, BR, BY, BZ, CA, CH, CN, CR, CU, CZ, DE, DK, DM, DZ, EE, ES, FI, GB, GD, GE, GH, GM, HR, HU, ID, IL, IN, IS, JP, KE, KG, KP, KR, KZ, LC, LK, LR, LS, LT, LU, LV, MA, MD, MG, MK, MN, MW, MX, MZ, NO, NZ, PL, PT, RO, RU, SD, SE, SG, SI, SK, SL, TJ, TM, TR, TT, TZ, UA, UG, US, UZ, VN, YU, ZA, ZW.
- (84) Designated States (regional): ARIPO patent (GH, GM, KE, LS, MW, MZ, SD, SL, SZ, TZ, UG, ZW), Eurasian patent (AM, AZ, BY, KG, KZ, MD, RU, TJ, TM), European patent (AT, BE, CH, CY, DE, DK, ES, FI, FR, GB, GR, IE, IT, LU, MC, NL, PT, SE, TR), OAPI patent (BF, BJ, CF, CG, CI, CM, GA, GN, GW, ML, MR, NE, SN, TD, TG).
- Published:
— With international search report.
— Before the expiration of the time limit for amending the claims and to be republished in the event of receipt of amendments.

[Continued on next page]

(54) Title: MEMBRANE FILTRATION ELEMENT HAVING SLEEVE ELEMENT AND SOCKET MEMBERS

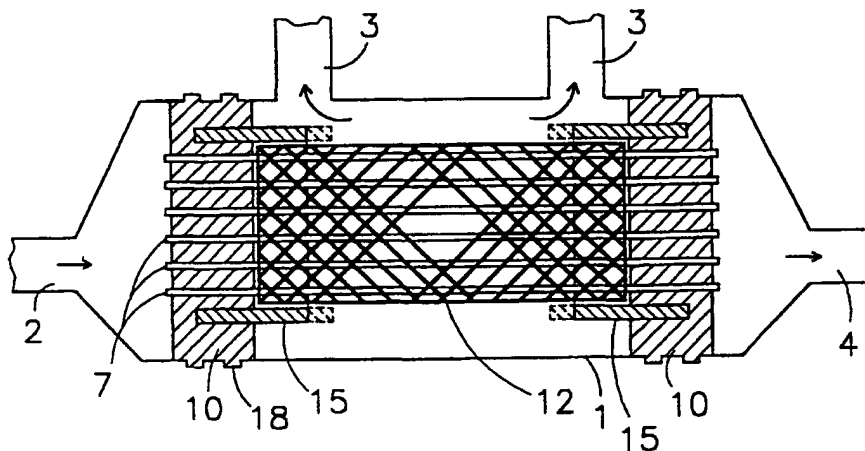

(57) Abstract: A membrane filtration unit comprises: a housing (1) having a feedstock inlet (2), a permeate outlet (3) and a retentate outlet (4); at least one bundle of tubular membranes (7) which is accommodated in the housing (1); sealing bodies (10) which hold end parts of the membranes (7) sealed in a fixed position with respect to the housing (1) and thus separate the housing (1) into separate spaces; and at least one flexible, permeable sleeve element (12) which encloses the bundle of membranes (7) and holds it together. The flexible, permeable sleeve element (12) encloses a centre part, which is situated between the securely held end parts, of the bundle of membranes (7). Socket members (15) are provided, which delimit transitional parts of the bundle of membranes (7), which transitional parts are situated at the location of the transitions from the securely held end parts to the enclosed centre part. Part of each socket member (15) is fixedly connected with respect to the housing (1) and part of each socket member (15) encloses an end of the sleeve element (12), in such a manner that the sleeve element (12) can move with respect to the enclosing socket member (15).

WO 01/32299 A1



For two-letter codes and other abbreviations, refer to the "Guidance Notes on Codes and Abbreviations" appearing at the beginning of each regular issue of the PCT Gazette.

Short title: Membrane filtration element having sleeve
element and socket members

The invention relates to a membrane filtration unit
5 for separating a feedstock which is fed past a large number
of tubular membranes into a permeate and a retentate.
Numerous variants of membrane filtration units are known.

By way of example, EP-B-0 181 470 has disclosed a
membrane filtration unit with a case-like housing in which
10 there is a bundle of 5,000-10,000 hollow membrane fibres.
End parts of the membrane fibres are embedded in resin-like
sealing bodies which separate the housing into separate
spaces, one which is in contact with the outer side and one
which is in contact with the inner side of the membrane
15 fibres.

A drawback of this known membrane filtration unit
is that there is a considerable risk of the membrane fibres
breaking during operation. The transitions from the embedded
parts of the membrane fibres to those parts of the membrane
20 fibres which are not embedded and extend between the
embedded parts are particularly fragile. This imposes limits
on process conditions (such as feedstock and backflush flow
rates, maximum operating temperature and feedstock and
backflush pressures) under which the unit can be used.

25 US-A-3, 832, 830 shows a membrane filtration unit
having a housing in which there is a bundle of more than a
million hollow membrane fibres. Once again, end parts of the
membrane fibres are embedded in resin-like sealing bodies.
The bundle of membrane fibres is enclosed by a flexible,
30 porous, elongate piece of tubing which extends over the
entire length of the bundle and is likewise embedded in the
resin-like sealing bodies. The flexible piece of tubing
holds the bundle of membrane fibres together and imparts a
certain rigidity and strength to these fibres. The piece of
35 tubing facilitates positioning the enormous number of
membrane fibres in the housing without the membrane fibres
in the bundle being pressed flat or damaged. To reduce the
risk of breakage at the location of the fragile transitional
parts between the embedded and unembedded parts of the

membrane fibres, the unit comprises elastic retaining elements which are arranged around the fragile transitional parts and part of which extend into the sealing bodies, to which they are fixedly connected by being embedded. At the
5 location of the transitional parts, the elastic retaining elements wrap taut around the bundle of membrane fibres and the piece of tubing surrounding them, serving primarily to prevent resin being able to penetrate into the unembedded part of the bundle during production of the sealing bodies.
10 As a result, the tightly wrapped transitional parts become inflexible.

A drawback of this known membrane filtration unit is that in practice it has been found that not only does the bundle of tightly wrapped transitional parts of the membrane
15 fibres become inflexible, but a large part of the flexibility of the part of the bundle which is enclosed only by the piece of tubing is also lost. In addition, there are, as it were, new fragile transitional parts of the membrane fibres formed in the vicinity of the unembedded ends of the
20 retaining elements, where there is a relatively high risk of the membrane fibres breaking. Furthermore, this membrane filtration unit is expensive and complex to produce.

The invention aims to overcome the abovementioned drawbacks and in particular to provide a membrane filtration
25 unit which is simple and functions well, enabling optimum process conditions to be combined with a minimum risk of the membranes breaking.

According to the invention, this object is achieved by a membrane filtration unit according to claim 1. The
30 membrane filtration unit comprises a housing in which one or more bundles of tubular membranes are situated. End parts of the membranes are held sealed in a fixed position with respect to the housing in a sealing body. A centre part, which extends between the securely held end parts, of the
35 bundle of membranes is to a large extent enclosed by a flexible, permeable sleeve element. At transitional parts between the securely held end parts and the enclosed centre part of the bundle of membranes, there are socket members, part of each of which is fixedly connected with respect to

the housing, and another part of each of which encloses an end of the sleeve element. The way in which the socket members enclose the sleeve element is such that the sleeve element can move slightly with respect to the socket members. Since the flexible sleeve element is rigidly connected neither to the sealing bodies nor to the socket members, a certain flexibility remains in the bundle of membranes, so that flow forces which act on the bundle of membranes in operation can be reduced. The sleeve element limits the freedom of movement, with the result that some rigidity and strength is imparted to the bundle of membranes, making the bundle less fragile. In addition, the sleeve element makes it easier to arrange the membranes in the housing. At the location of the transitional parts, the sleeve element is moveably delimited between the socket members. In that area, the enclosing limitations ensure that there is a considerably reduced risk of the membranes breaking. Therefore, the invention is partly based on the insight that the risk of membranes in a membrane filtration unit breaking can be minimized by providing the membranes as a bundle with a flexible enclosure comprising a permeable sleeve element which, at the location of fragile transitional parts of the membranes, is moveably delimited by means of socket members.

The socket member preferably encloses the sleeve element in such a manner that they can slide in the longitudinal direction with respect to one another. In this case, the bundle of membranes is delimited by the socket members in a direction perpendicular to the longitudinal direction of the membranes, while during operation the forces can be reduced by the sleeve element sliding in the socket member. If the connection were rigid, the tendency of the tubular membranes to expand under conditions of use (such as moisture, temperature and pressure) could cause them to break, but according to the invention this tendency can be absorbed by means of the sleeve element sliding.

Advantageously, at least that part of the socket member which encloses the sleeve element is permeable. Consequently, the action of the enclosed parts of the

membranes is scarcely restricted, if at all, by the socket members, the effective membrane surface area remains as large as possible and there are no longer any dead spaces.

Further preferred embodiments are defined in the
5 subclaims.

The invention will be explained in more detail with reference to the appended drawing, in which:

Figure 1 is a highly diagrammatic view, in longitudinal section, of a membrane filtration unit
10 according to the invention with one bundle of tubular membranes;

Figure 2 shows a view corresponding to that shown in Figure 1 of a variant embodiment having a plurality of bundles of tubular membranes;

15 Figure 3 shows a cross-sectional view on line III-III in Figure 2;

Figure 4 shows a highly diagrammatic partial view, corresponding to that shown in Figure 1, of a variant embodiment with a tube plate;

20 Figure 5 shows a cross-sectional view on line V-V in Figure 4; and

Figure 6 shows a highly diagrammatic view, corresponding to that shown in Figures 3 and 5, of a variant embodiment having a plurality of socket members which are
25 connected to one another and to a housing.

The membrane filtration unit shown in Figure 1 comprises a housing 1 having a feedstock inlet 2, permeate outlets 3 and a retentate outlet 4. Inside the housing 1 there is a bundle comprising tubular membranes 7, only a few
30 of which are illustrated. The tubular membranes are formed, for example, by self-supporting membranes, such as hollow fibres or capillaries. End parts of the membranes 7 are embedded in sealing bodies 10. Between the securely held end parts of the membranes 7 there are centre parts which, as a
35 bundle, are enclosed and held together by a flexible, permeable sleeve element 12. The sleeve element 12 is not embedded in the sealing bodies 10. The unit also comprises socket members 15. Part of each socket member 15 is embedded in the sealing body 10, and another part of each socket

member 15 encloses an end of the sleeve element 12. The socket member 15 and the end of the sleeve element 12 are not connected to one another. The way in which the end of the sleeve element 12 is enclosed is such that it can slide
5 inside the socket member 15 in the longitudinal direction of the bundle of membranes 7. This ability of the sleeve element to slide means that a certain flexibility is retained in the bundle of membranes 7, by means of which flow forces which are exerted on the bundle of membranes
10 during operation can be reduced. The transitional parts at the location of the transitions from the securely held end parts to the enclosed centre parts of the membranes 7 are virtually unable to move in a direction perpendicular to the longitudinal direction of the membranes 7, since in this
15 direction they are delimited by the socket member 15. It should be noted that, for the sake of clarity, the clearance between the sleeve element 12 and the socket member 15 has been portrayed as larger than that which is actually required in practice for the unit to operate successfully.
20 As a result, there is sufficient protection against the membranes 7 breaking off or becoming damaged at these transitional parts. The measures according to the invention make it possible to use the membrane filtration unit under more optimum operating conditions. The feedstock flowrates,
25 the operating temperature and the feedstock pressures may be greater than in the prior art. It is also possible to use greater backflush flowrates and backflush pressures during a cleaning operation in which a cleaning liquid, for example permeate, is passed through the unit in the reverse
30 direction. If desired, a feedstock medium which is to be filtered may also flow through the membrane filtration unit in the opposite direction. By way of example, the left-hand tube 3 can be used as a feedstock inlet, while the right-hand tube 3 is used to discharge retentate. The tubes
35 2 and 4 can both be used for discharging permeate.

That part of the socket member 15 which encloses the sleeve element 12 is preferably permeable. In this way, the effective membrane surface area of the bundle of membranes 7 can be utilized optimally. Furthermore, those

parts of the socket member 15 which enclose the sleeve element 12 are preferably designed to be sufficiently long, as indicated by dashed lines in Figure 1, for them to extend across the front of the entire permeate outlet 3. The socket members 15 can then advantageously be used as buffer plates, for example if the permeate outlets 3 are used to supply a cleaning liquid during a cleaning operation. The cleaning liquid can then be supplied under high pressure and/or at high flow rates without there being any risk of a forceful incoming flow damaging the bundle of membranes 7.

The sealing body 10 is directly connected to the housing 1. To improve the connection between the sealing body and the housing 1, circumferential grooves 18 are provided in the housing 1. The circumferential grooves 18 increase the contact area between the housing 1 and the sealing body 10 and prevent axial sliding of the sealing body 10 during operation. The latter effect is important in particular because the feedstock and permeate pressures may and can be greater by virtue of the invention, and consequently the forces acting on the sealing body 10 may also be greater.

That part of the socket member 15 which is embedded in the sealing body 10 is preferably produced with an open or porous structure. For example, if the sealing body 10 is made from a resin-like substance, this substance can penetrate into the open or porous structure in the socket member 15. This leads to a good connection between the socket member 15 and the sealing body 10.

In the variant shown in Figures 2 and 3, the membrane filtration unit comprises eight bundles of tubular membranes 20. Those ends of the membranes 20 which lie at one end are embedded in one sealing body 21. Each bundle of membranes 20 is enclosed, in the same way as in Figure 1, by a flexible, permeable sleeve element 22, the outer ends of which are delimited by socket members 23 in such a manner that it can slide in the longitudinal direction. The plurality of bundles of membranes 20 are accommodated in a housing 25 which comprises a feedstock inlet 26, a retentate outlet 27 and a central permeate outlet tube 28. The outlet

tube 28 extends in the longitudinal direction through the centre of the housing 25 and is provided with a plurality of inflow openings 29 in the space between the sealing bodies 21.

5 Advantageously, the socket members 23 which lie at the same end are connected either to one another, or each to the central permeate outlet tube 28, or to one another and to the central permeate outlet tube 28. In this way, particularly if combined with the abovementioned possibility
10 of porous or spongy socket members, the result is an assembly of socket members 23 which serves as reinforcement for the material of the sealing body 21. The rigidity and strength of the sealing body 21 increases as a result. This in turn has the advantage that the body can be of thinner
15 design which on the one hand is of benefit to the effective membrane surface area and on the other hand creates a unit which can be produced at lower cost. Another advantage is that it is possible to use larger module diameters without having to have a thicker sealing body. In a variant, the
20 socket members are separately or jointly attached to the inner side of the housing 25, for example by means of adhesive bonding.

The socket member 23 is advantageously made from a material which is rigid compared to the sleeve element 22.
25 The socket members 23 are formed in such a manner that they impart a desired shape to the less rigid sleeve elements 22. The advantage of this can be seen, for example, from Figure 3, which shows that the plurality of bundles of membranes 20 are accommodated in an optimally packed arrangement around the permeate outlet tube 28 in the housing 25. The socket
30 members 23 are made, for example, from a plastically deformable material.

The membrane filtration unit shown in Figures 2 and 3 can easily be adapted in such a manner that incoming flow
35 in the opposite direction and/or backflushing with a cleaning liquid becomes possible. In this case, the central tube 28 can be used as a feedstock inlet, and the tubes 26 and 27 can be used as permeate outlets. As a result of the housing 25 being provided with an additional outlet in its

centre part, this outlet can be used as a retentate outlet and medium can flow into the entire unit in the opposite direction.

5 Figures 4 and 5 show the left-hand end part of a membrane filtration unit with four bundles of membranes 40. At the location of the ends of the membranes 40, there is a tube plate 41 which is fixedly connected to a housing 42. The tube plate 41 comprises four cutouts 44. An outer part of each cutout 44 is intended to accommodate and be
10 connected in a sealed manner to a sealing body 45 in which the end parts of the membranes 40 are embedded. An inner part of each cutout 44 is intended to moveably delimit a sleeve element 46 which encloses the bundle of membranes 40. Together with the peripheral walls of the cutouts 44, the
15 tube plate 41 forms an integral assembly of socket members. The tube plate 41 is easy to produce. Moreover, an assembly of a plurality of bundles of membranes 40, tube plates 41 and sealing bodies 45 can be prepared outside the housing
20 42, after which all that remains is to connect the tube plates 41 to the housing 42 in a sealed manner. Moreover, if these connections are made to be dismantleable, it is possible to carry out repairs or maintenance work on the interior of the membrane filtration unit.

25 Figure 5 also clearly shows that the cutouts 44 in the tube plate 41 are shaped in such a manner that the bundles of membranes 40 can be positioned in a closely packed arrangement in the housing 42.

30 The tube plate shown in Figures 4 and 5 may be made from a solid material but is advantageously made from a porous or spongy material, so that it can be strongly reinforced with the material of the sealing element. In a variant, the tube plate is made from the same material as the material for the sealing bodies. In this case, during a
35 production operation, the ends of the sleeve elements have to be prepared in such a manner that they are not permanently connected to the material of the sealing body or the tube plate. This can be achieved, for example, by

lubricating the ends of the sleeve element with vaseline, teflon or the like.

Figure 6 shows a cross section through a substantially cylindrical housing 60 in which seven bundles of tubular membranes 61 are accommodated in an optimally packed arrangement. Each bundle of membranes 61 is enclosed by a sleeve element 62 which, at its end, is moveable delimited by a socket member 63. The socket members 63 are in this case likewise of substantially cylindrical design. The plurality of socket members 63 are connected to one another and to the housing 60, as diagrammatically indicated by thick spots 64. The assembly of socket members 63 is rigid and strong and, furthermore, reinforces the housing 60. Like the embodiment shown in Figures 2 and 3, the assembly may advantageously be used as a reinforcement for the material of one sealing body in which the assembly is partially embedded. The embedded socket members are preferably of permeable design, so that the material of the sealing body can penetrate successfully from all sides and can form an integral, strong unit with the assembly of socket members.

A problem which is frequently encountered when embedding ends of tubular membranes in a resin-like sealing body in a housing is that, particularly if there are relatively great amounts of resin, cooling leads to the formation of shrinkage cracks at the location where the sealing body is connected to the housing wall. Surprisingly, it has been found that this problem is overcome according to the invention by the use of an end plate with a porous or spongy structure in which a cutout is provided for accommodating a sealing body with embedded membrane end parts. The porous or spongy structure not only provides a very good connection between the material of the sealing body and the end plate, but also prevents the formation of shrinkage cracks. The use of a sealing body with a reinforcement means that the amount of resin-like material required is less than without a reinforcement (while retaining the mechanical properties), so that this smaller quantity means that the temperature increase becomes less

critical, leading to a production process which can be implemented more successfully. The end plates with a porous or spongy structure can be used to good effect both in membrane filtration units according to the invention with
5 moveably delimited sleeve elements and in other types of membrane filtration units, in which sleeve elements may optionally be embedded in the sealing body or may be omitted altogether.

Besides the embodiments shown, numerous variants
10 are possible. In a variant which is not shown, the socket members or the cutouts in the tube plate are of cylindrical design and the bundles of membranes accordingly extend in the form of a cylinder through the housing. In another variant, the individual socket members are made from a
15 material, for example glass fibre or a woven stocking, which is securely anchored on the side of the sealing element, while flexibility and movement in the longitudinal direction are possible on the side of the sleeve element. As an alternative to the slideable connection between the socket
20 member and the sleeve element, these components may then be moveably connected to one another. As an alternative to a substantially straight bundle of tubular membranes with sealing bodies provided at opposite ends, it is also possible for the bundle to be arranged in a curve, for
25 example even in a U shape, in which case the two ends are positioned next to one another and can then be embedded in a single sealing body.

The invention provides a highly advantageous membrane filtration unit which can be used for prolonged
30 periods under high pressures and with high yields for filtering a feedstock liquid. The risk of leaks resulting from damage to the membranes is minimized on account of sleeve elements which enclose bundles of membranes being moveably delimited.

CLAIMS

1. Membrane filtration unit, comprising:
- a housing (1) having a feedstock inlet (2), a permeate outlet (3) and a retentate outlet (4);
 - at least one bundle of tubular membranes (7) which is accommodated in the housing (1);
 - sealing bodies (10) which hold end parts of the membranes (7) sealed in a fixed position with respect to the housing (1) and thus separate the housing (1) into separate spaces, which spaces are in contact with the inner side or the outer side of the membranes (7) and are in open communication with the feedstock inlet (2) or the permeate and retentate outlets (3 and 4, respectively); and
 - at least one flexible, permeable sleeve element (12) which encloses the bundle of membranes (7) and holds them together;
- characterized in that the flexible, permeable sleeve element (12) encloses a centre part, which is situated between the securely held end parts, of the bundle of membranes (7), and in that socket members (15) are provided, which delimit transitional parts of the bundle of membranes (7), which transitional parts are situated at the location of the transitions from the securely held end parts to the enclosed centre part, part of each socket member (15) being fixedly connected with respect to the housing (1), and part of each socket member enclosing an end of the sleeve element (12) in such a manner that the sleeve element (12) can move with respect to the enclosing socket member (15).
2. Membrane filtration unit according to claim 1, in which the socket member (15) encloses the end of the sleeve element (12) in such a manner that the sleeve element (12) can slide in the longitudinal direction of the bundle of membranes (7) with respect to the enclosing socket member (15).
3. Membrane filtration unit according to claim 1 or 2, in which that part of the socket member which encloses the sleeve element (12) is permeable.

4. Membrane filtration unit according to one of claims 1-3, in which the sealing body (10) is directly connected to the housing (1), and part of the associated socket member (15) is embedded in the material of the sealing body (10).

5. Membrane filtration unit according to claim 4, in which the embedded part of the socket member is made from a material which is permeable.

10 6. Membrane filtration unit according to one of claims 1-3, in which the socket member is directly connected to the housing, and the associated sealing member adjoins the socket member in a sealed manner.

15 7. Membrane filtration unit according to one of the preceding claims, in which the socket member is made from a material which is rigid compared to the sleeve element.

20 8. Membrane filtration unit according to one of the preceding claims, in which a plurality of bundles of tubular membranes (20) are provided.

25 9. Membrane filtration unit according to claim 8, in which the socket members (23) which are located at the same end are connected to one another.

30 10. Membrane filtration unit according to one of the preceding claims, in which the socket members which are located at the same end form part of an integrated tube plate (41), in which cutouts (44) are provided which are such that each sleeve element (46) is moveably delimited in part of an associated cutout (44), while in another part of this cutout (44) the associated bundle of tubular membranes (40) is connected to the tube plate (41) in a sealed manner by means of the associated sealing body (45).

11. Membrane filtration unit according to one of the preceding claims, in which the feedstock inlet or the

permeate or retentate outlet (3) of the space which is in contact with the outer side of the membranes (7) is provided at the location of a socket member which, during operation or during a cleaning action, serves as a buffer plate for
5 protecting the bundle of membranes from an incoming flow of liquid.

12. Membrane filtration unit according to one of the preceding claims, in which the tubular membranes are
10 self-supporting.

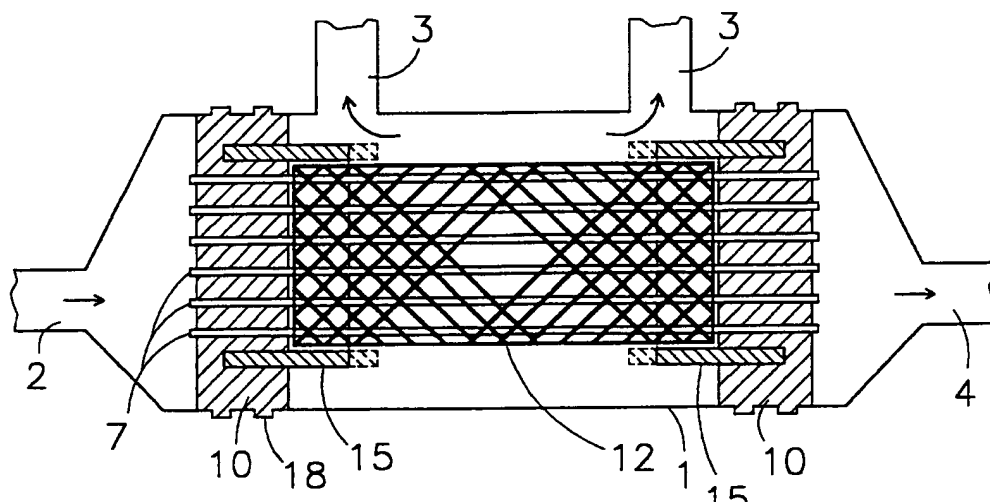

Fig 1

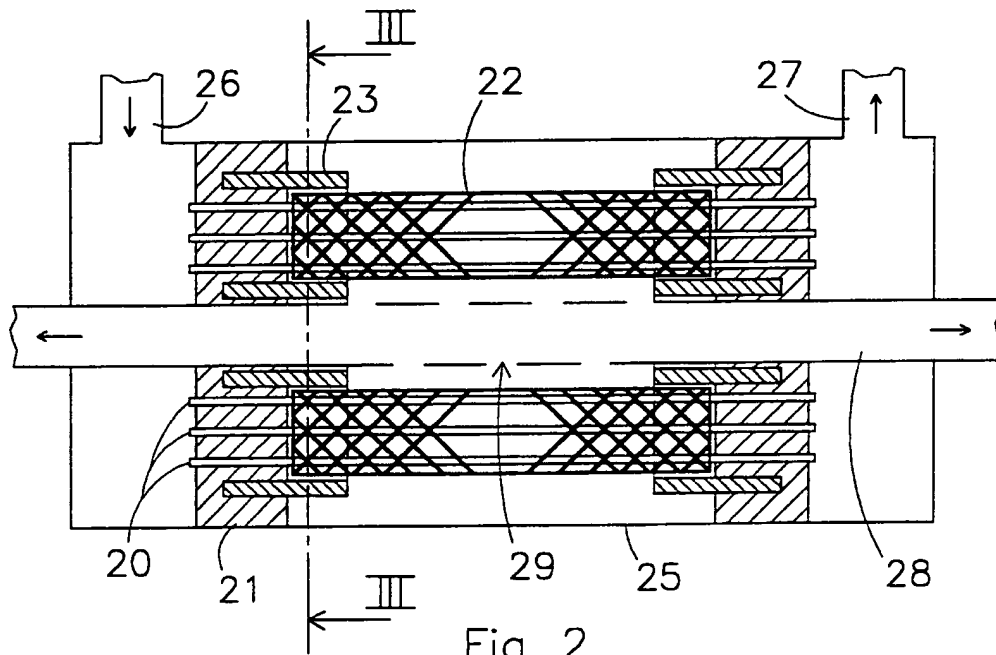

Fig 2

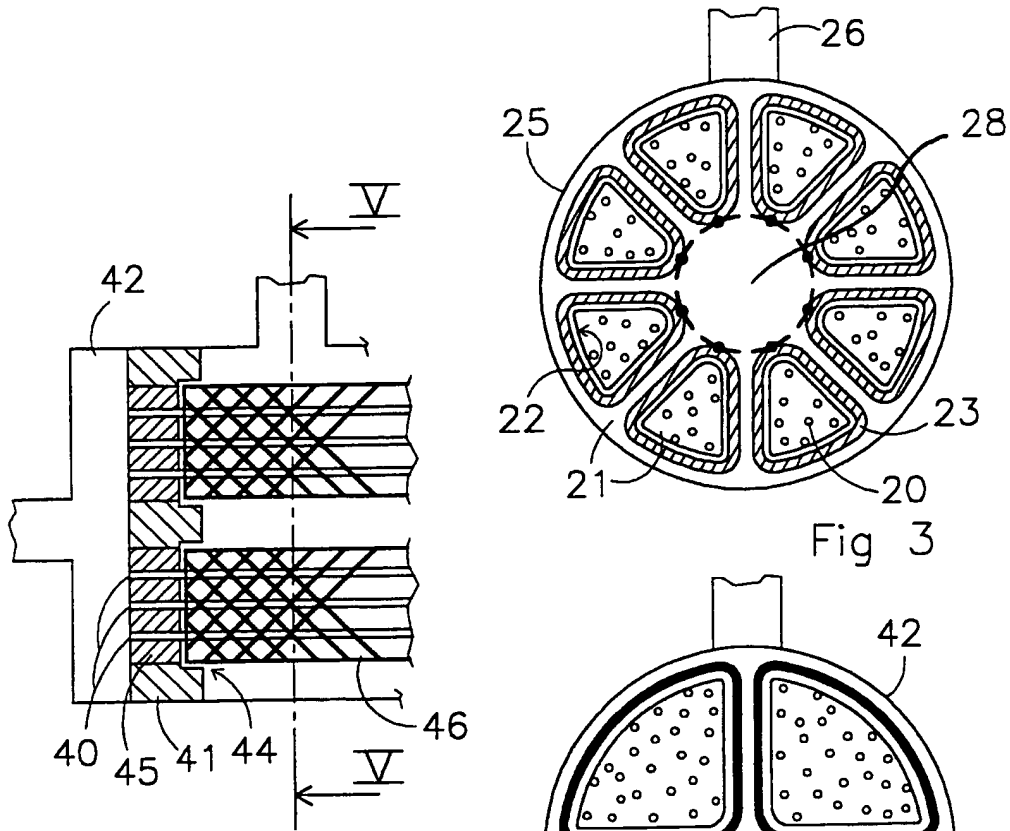

Fig 4

Fig 3

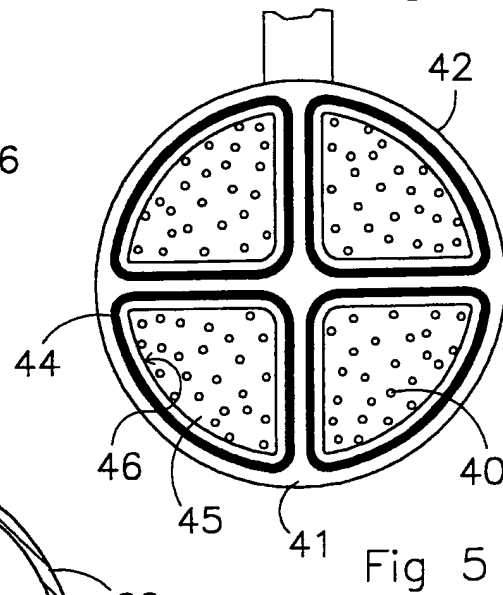

Fig 5

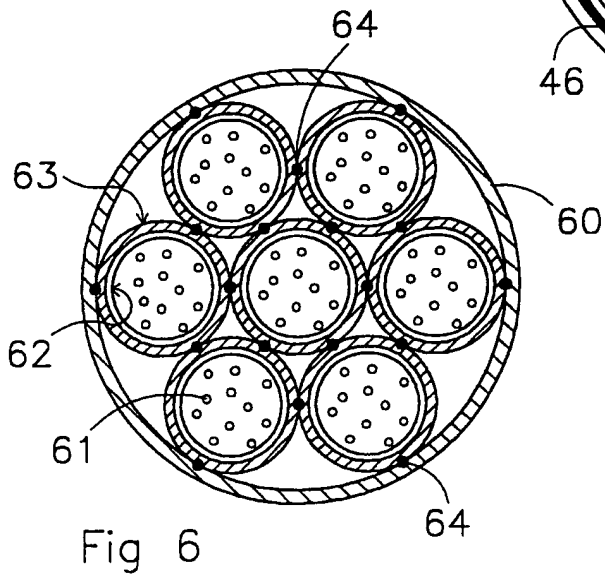

Fig 6

INTERNATIONAL SEARCH REPORT

Internatic Application No
PCT/NL 00/00794

A. CLASSIFICATION OF SUBJECT MATTER
 IPC 7 B01D63/02 B01D63/06

According to International Patent Classification (IPC) or to both national classification and IPC

B. FIELDS SEARCHED

Minimum documentation searched (classification system followed by classification symbols)
 IPC 7 B01D

Documentation searched other than minimum documentation to the extent that such documents are included in the fields searched

Electronic data base consulted during the international search (name of data base and, where practical, search terms used)

PAJ, EPO-Internal, WPI Data

C. DOCUMENTS CONSIDERED TO BE RELEVANT

Category *	Citation of document, with indication, where appropriate, of the relevant passages	Relevant to claim No.
Y	PATENT ABSTRACTS OF JAPAN vol. 1999, no. 12, 29 October 1999 (1999-10-29) -& JP 11 179164 A (NITTO DENKO CORP), 6 July 1999 (1999-07-06) abstract; figures 1-4 paragraphs '0002!-'0004!', '0006!-'0010!; example -& DATABASE WPI Derwent Publications Ltd., London, GB; AN 1999-437848 XP002143052 abstract <div style="text-align: center;">--- -/--</div>	1,2,4,7

Further documents are listed in the continuation of box C.

Patent family members are listed in annex.

* Special categories of cited documents :

- *A* document defining the general state of the art which is not considered to be of particular relevance
- *E* earlier document but published on or after the international filing date
- *L* document which may throw doubts on priority claim(s) or which is cited to establish the publication date of another citation or other special reason (as specified)
- *O* document referring to an oral disclosure, use, exhibition or other means
- *P* document published prior to the international filing date but later than the priority date claimed

- *T* later document published after the international filing date or priority date and not in conflict with the application but cited to understand the principle or theory underlying the invention
- *X* document of particular relevance; the claimed invention cannot be considered novel or cannot be considered to involve an inventive step when the document is taken alone
- *Y* document of particular relevance; the claimed invention cannot be considered to involve an inventive step when the document is combined with one or more other such documents, such combination being obvious to a person skilled in the art.
- *&* document member of the same patent family

Date of the actual completion of the international search

9 April 2001

Date of mailing of the international search report

18/04/2001

Name and mailing address of the ISA

European Patent Office, P.B. 5818 Patentlaan 2
 NL - 2280 HV Rijswijk
 Tel. (+31-70) 340-2040, Tx. 31 651 epo nl,
 Fax: (+31-70) 340-3016

Authorized officer

Hoornaert, P

INTERNATIONAL SEARCH REPORT

Internatic Application No

PCT/NL 00/00794

C.(Continuation) DOCUMENTS CONSIDERED TO BE RELEVANT		
Category *	Citation of document, with indication, where appropriate, of the relevant passages	Relevant to claim No.
Y	PATENT ABSTRACTS OF JAPAN vol. 012, no. 433 (C-543), 15 November 1988 (1988-11-15) -& JP 63 158103 A (DAICEL CHEM IND LTD), 1 July 1988 (1988-07-01) abstract; figures -& DATABASE WPI Derwent Publications Ltd., London, GB; AN 1988-223699 XP002143053 abstract	1,2,4,7
A	EP 0 481 433 A (ASAHI CHEMICAL IND) 22 April 1992 (1992-04-22) abstract; figures 1,2 page 2, line 30 - line 37 page 6, line 17 - line 25 page 7, line 17 - line 24	1,3-5,7, 11
A	US 4 578 190 A (FOWLER JAMES D) 25 March 1986 (1986-03-25) the whole document	1-3,7,11
A	EP 0 009 374 A (ALBANY INT CORP) 2 April 1980 (1980-04-02) abstract; figures 1-7,14 page 14, line 27 -page 16, line 8 page 17, line 15 - line 18	1,2,6,7
A	EP 0 288 030 A (DOW CHEMICAL CO) 26 October 1988 (1988-10-26) the whole document	1
A	PATENT ABSTRACTS OF JAPAN vol. 012, no. 059 (C-478), 23 February 1988 (1988-02-23) -& JP 62 204804 A (DAICEL CHEM IND LTD), 9 September 1987 (1987-09-09) abstract; figures -& DATABASE WPI Derwent Publications Ltd., London, GB; AN 1987-294284 XP002143054 abstract	1,3,4,11

-/--

INTERNATIONAL SEARCH REPORT

Internatic	Application No
PCT/NL	00/00794

C.(Continuation) DOCUMENTS CONSIDERED TO BE RELEVANT		
Category *	Citation of document, with indication, where appropriate, of the relevant passages	Relevant to claim No.
A	PATENT ABSTRACTS OF JAPAN vol. 017, no. 042 (C-1020), 26 January 1993 (1993-01-26) -& JP 04 256424 A (NITTO DENKO CORP), 11 September 1992 (1992-09-11) abstract; figures -& DATABASE WPI Derwent Publications Ltd., London, GB; AN 1992-353902 XP002143055 abstract ----	1,8,10
A	PATENT ABSTRACTS OF JAPAN vol. 1995, no. 08, 29 September 1995 (1995-09-29) -& JP 07 124445 A (DAICEL CHEM IND LTD), 16 May 1995 (1995-05-16) abstract; figures -& DATABASE WPI Derwent Publications Ltd., London, GB; AN 1995-211792 XP002143056 abstract ----	1,8
A	US 3 832 830 A (GEROW J) 3 September 1974 (1974-09-03) cited in the application the whole document -----	1,4,8,11

INTERNATIONAL SEARCH REPORT

Information on patent family members

Internatic Application No

PCT/NL 00/00794

Patent document cited in search report	Publication date	Patent family member(s)	Publication date
JP 11179164 A	06-07-1999	NONE	
JP 63158103 A	01-07-1988	JP 1868538 C JP 5082247 B	26-08-1994 18-11-1993
EP 0481433 A	22-04-1992	JP 4150927 A JP 7075657 B CA 2053422 A,C DE 69125997 D DE 69125997 T US 5143612 A	25-05-1992 16-08-1995 16-04-1992 12-06-1997 18-12-1997 01-09-1992
US 4578190 A	25-03-1986	NONE	
EP 0009374 A	02-04-1980	US 4207192 A US 4210536 A US 4220489 A AT 7575 T AT 5511 T AT 5512 T CA 1154692 A CA 1170194 A DE 2966482 D DE 2966483 D DE 2967006 D EP 0038611 A EP 0038612 A FI 792855 A IL 58247 A IL 68846 A IL 68847 A JP 1647640 C JP 2002835 A JP 3012928 B MX 155500 A NO 792972 A,B, NO 832171 A,B, NO 832172 A,B, SE 447633 B SE 7907563 A US 4631128 A JP 1033206 B JP 1550030 C JP 55061902 A	10-06-1980 01-07-1980 02-09-1980 15-06-1984 15-12-1983 15-12-1983 04-10-1983 03-07-1984 12-01-1984 12-01-1984 28-06-1984 28-10-1981 28-10-1981 20-03-1980 28-02-1986 31-12-1986 31-12-1986 13-03-1992 08-01-1990 21-02-1991 25-01-1988 20-03-1980 20-03-1980 20-03-1980 01-12-1986 20-03-1980 23-12-1986 12-07-1989 09-03-1990 10-05-1980
EP 0288030 A	26-10-1988	US 4758341 A JP 63283709 A	19-07-1988 21-11-1988
JP 62204804 A	09-09-1987	NONE	
JP 04256424 A	11-09-1992	NONE	
JP 07124445 A	16-05-1995	NONE	
US 3832830 A	03-09-1974	DE 2346982 A FR 2200034 A GB 1439487 A JP 49069550 A	04-04-1974 19-04-1974 16-06-1976 05-07-1974